

Boiler Back-up

*Heating only

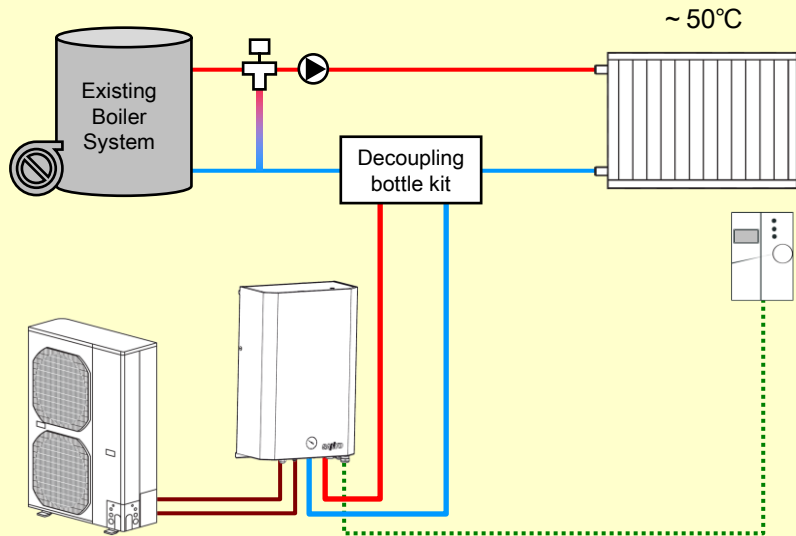

Boiler back-up system (from Mid 2010)

◆ Product

Different model from current line-up of Split type module

◆ Unit appearance

Same appearance, but the electric heater is not in the body.

◆ Operation

- Split module system supports the existing boiler system operation
- Pre-heating for boiler inlet water
- Maintain the system operation only by Split module for low~middle temperature demand condition
- Boiler operation is directly managed by split module
- Boiler provides production of DHW