

1-3-4 Domestic Hot Water Production Kit (DHWPk)

• 300-litre tank:

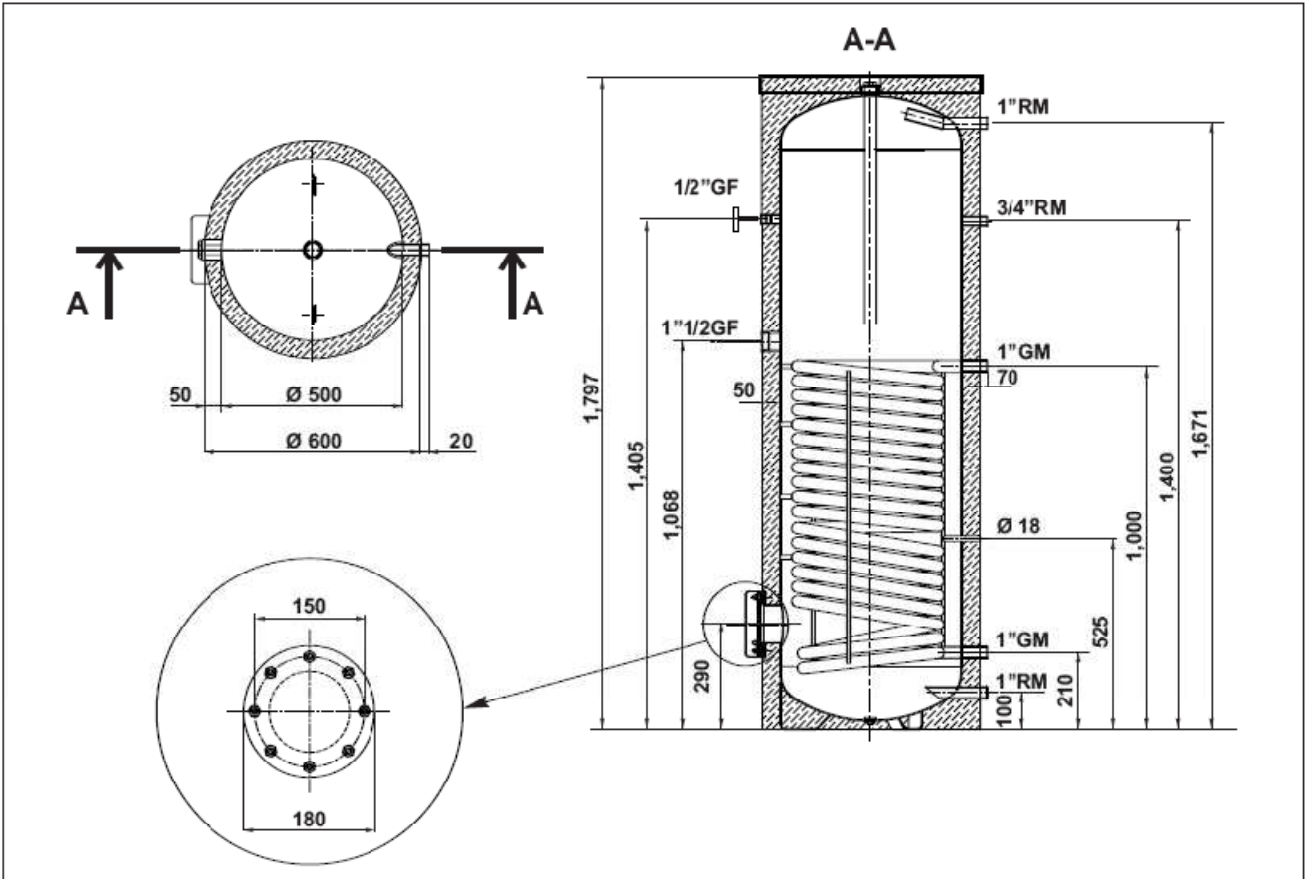

• 500-litre tank:

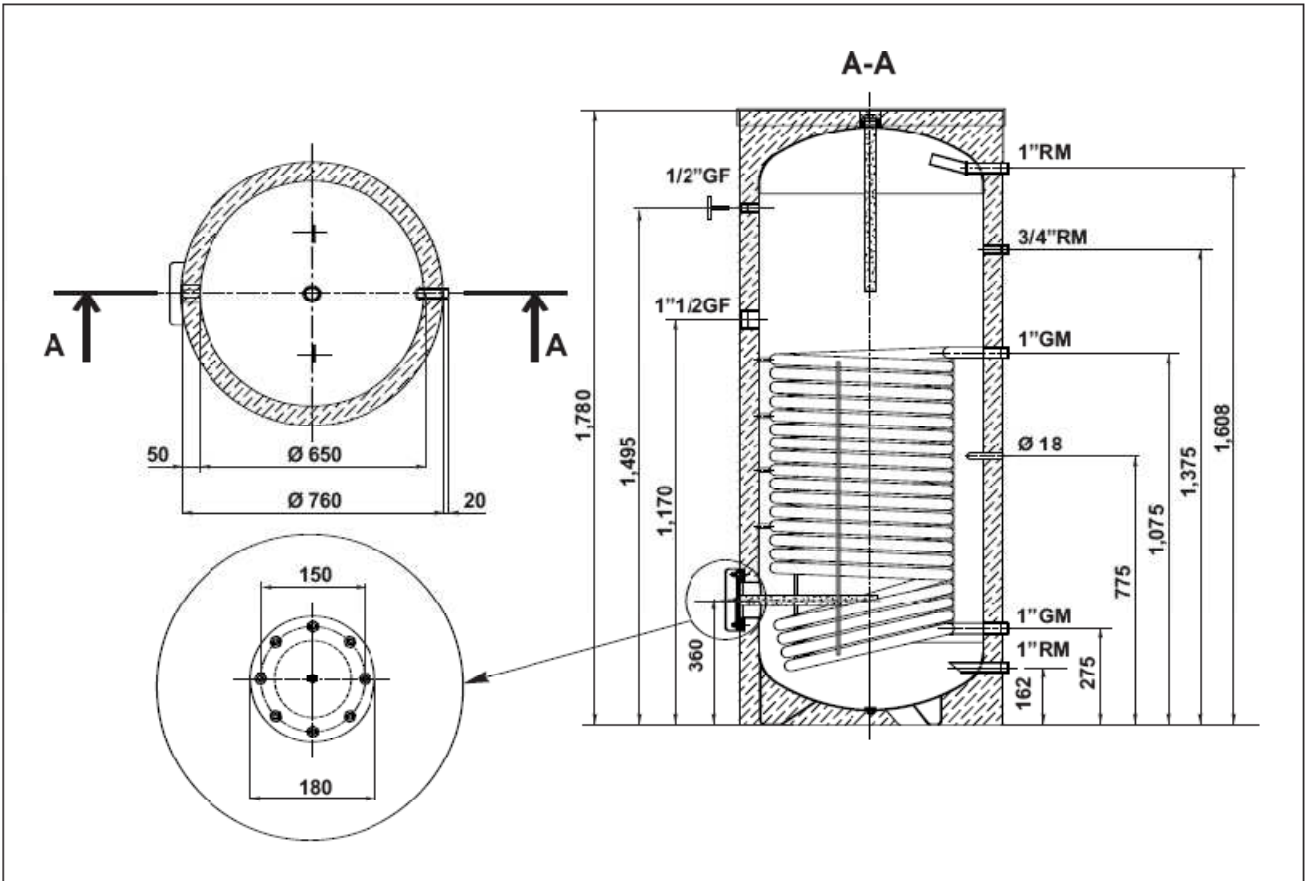

1-4-3-7 Application : 1 Zone Radiators Low Temperature + Domestic Hot Water (DHW)

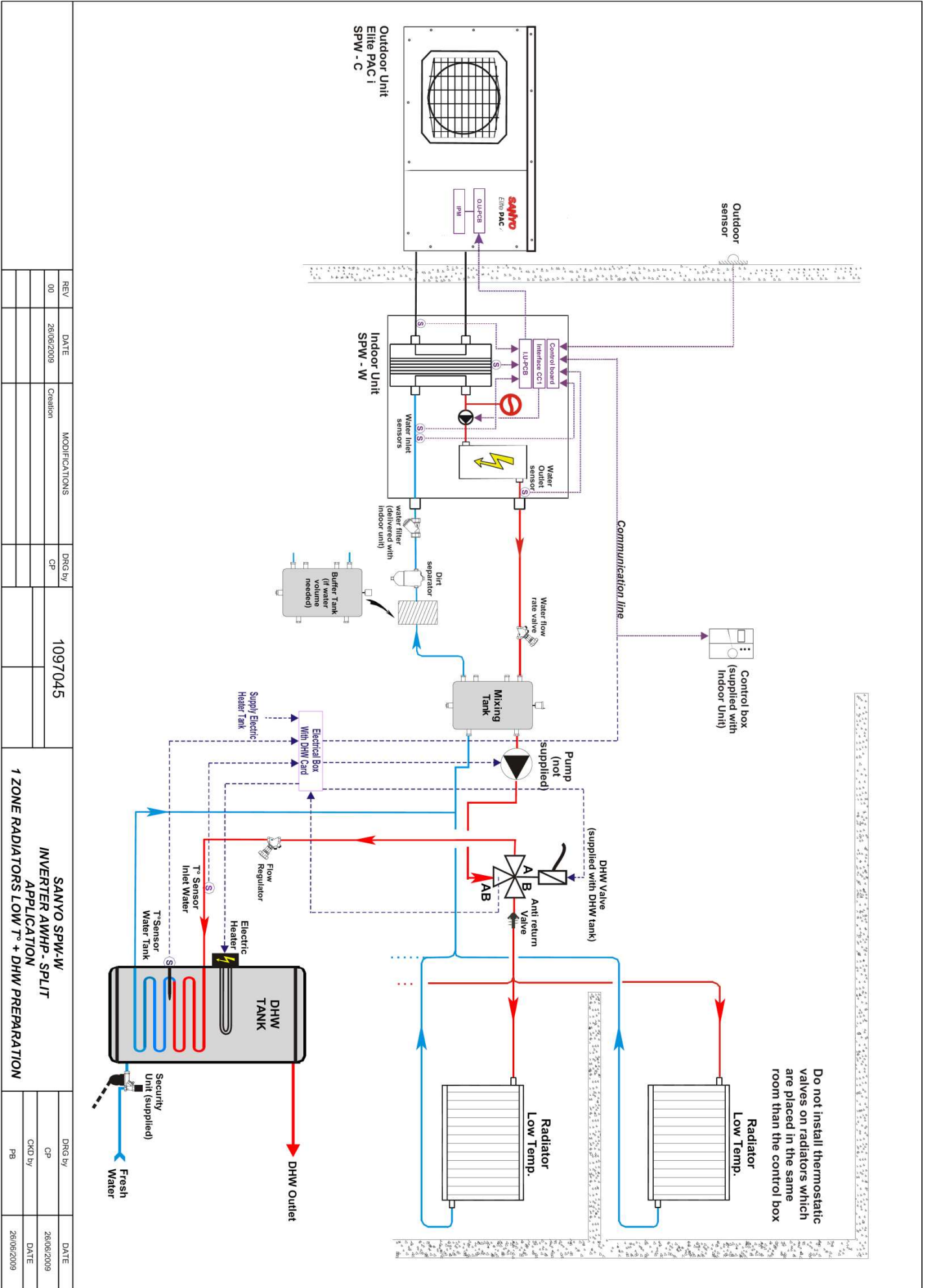

|     |            |               |        |         |   |         |            |
|-----|------------|---------------|--------|---------|---|---------|------------|
| REV | DATE       | MODIFICATIONS | DRG by | 109T045 | SANYO SPW-W<br>INVERTER AWHP - SPLIT<br>APPLICATION | DRG by  | DATE       |
| 00  | 26/06/2009 | Creation      | CP     |         | 1 ZONE RADIATORS LOW T° + DHW PREPARATION           | CP      | 26/06/2009 |
|     |            |               |        |         |   | CHKD by | DATE       |
|     |            |               |        |         |   | PB      | 26/06/2009 |

## 70600118 (35L) - 70600218 (70L) Buffer or mixing tank

### DESCRIPTION :

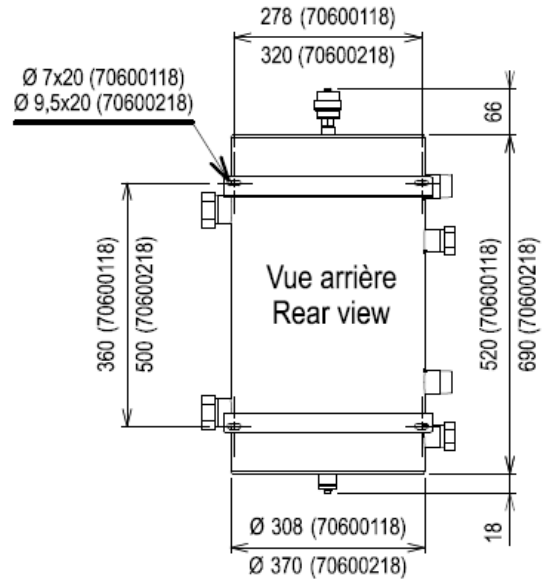
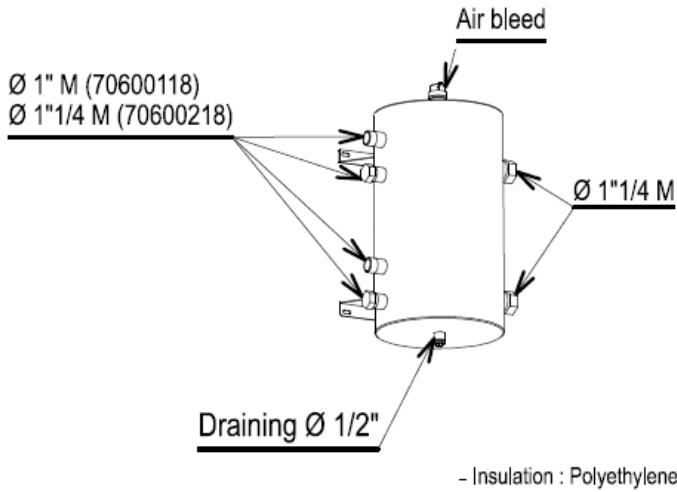

### INSTALLATION :

#### BUFFER TANK

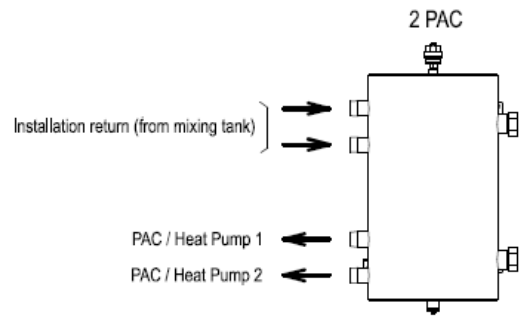
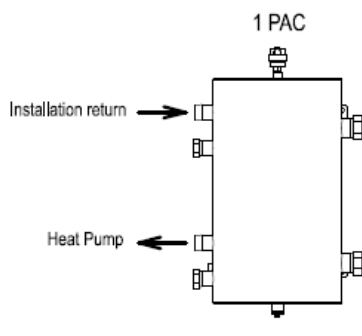

#### MIXING TANK

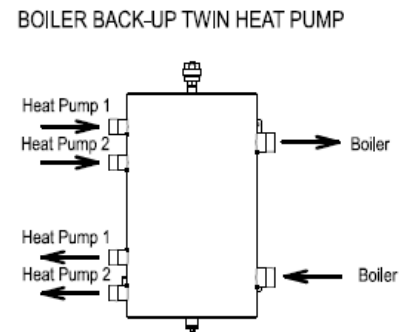
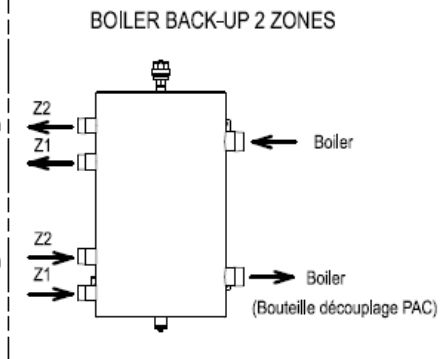
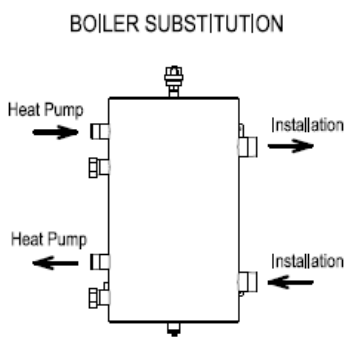

1011528-00